

PolyBlend® M Series
Polymer Feed System

A Generation Ahead

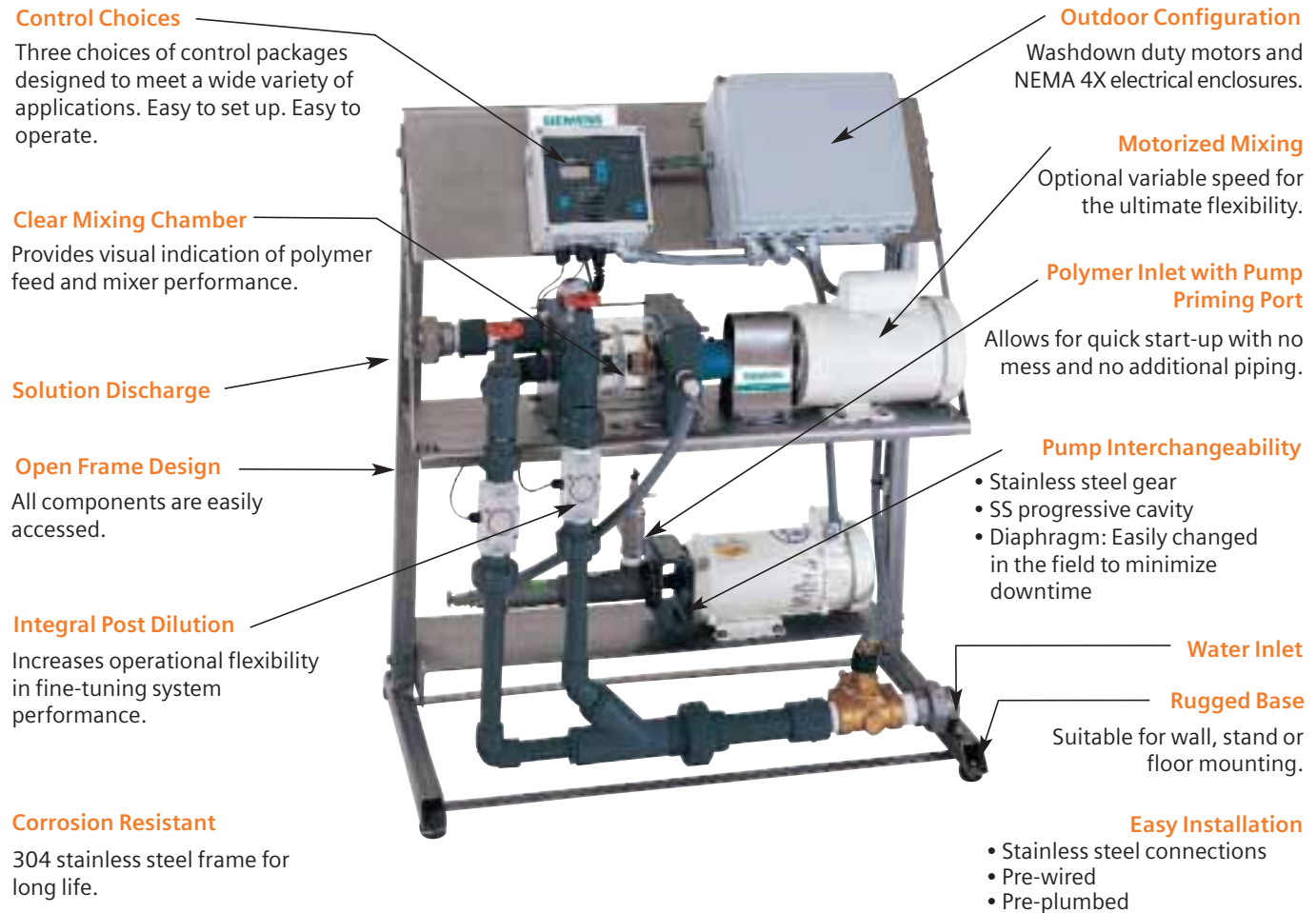

The new PolyBlend® M Series liquid polymer feed system is the best product available to handle your liquid/solid separation needs. The M Series feeder combines Siemens' proven motorized mixing technology with precise controls, a variety of pump offerings and an easy-to-service open-frame design. Then Siemens adds two unique options: variable speed mixing and automatic dosage control with constant solution strength.

Polymer Evolution Not Just a Theory

Chemists will continue to refine existing polymers and develop new ones, just as they have for more than 35 years. Operators should demand a polymer feeder that can keep up with breakthroughs in polymer technology for years to come. The PolyBlend® M Series feeder is ready to handle new polymer developments: ultra-high molecular weights, different charge densities, and even totally new chemistries.

The PolyBlend® M Series polymer feeder comes standard with a constant speed motor ideal for today's liquid polymers. But as polymer needs change and as new polymers are developed, the PolyBlend® M Series system can be quickly field adapted. Specify the optional variable speed drive right from the beginning or add it later. Upgrading to the variable speed design can be done in the field.

Patented Motorized Polymer Mixer

Optional Advanced Controls

Whether you adjust the PolyBlend® M Series polymer feed system output remotely via 4 - 20 mA signal or right at the unit, water flow and polymer feed increase and decrease together, automatically maintaining a constant solution strength. Even primary and secondary dilution water are kept at the same ratio as output is adjusted. See separate Control Selection Equipment Specification data sheet for more information on the three control options.

Multi-Zone Mixing Chamber

The PolyBlend® M Series polymer feed system uses Siemens' patented multi-zone mixing. The first zone exposes the polymer to a high energy environment to minimize agglomeration. Reduced mixing energy in the second zone protects the fragile polymer chains from fracturing, making more polymer available for work. The baffling is designed to create a tapered mixing regime. The optional variable speed mixing optimizes the hydration process within each zone regardless of the type of polymer in use.

Primary Mixing Zone

High energy mixing ensures fully activated polymer. Flow pattern and baffling limit exposure to high energy.

High Speed Open Vane Impeller

High energy mixing at the point of initial wetting to expose individual polymer particles to dilution water and prevent agglomeration.

Water Injection Point

Water is drawn into the impeller throat to mix with polymer.

Polymer Injection Point

Polymer is injected into the impeller to increase hydration of polymer particles.

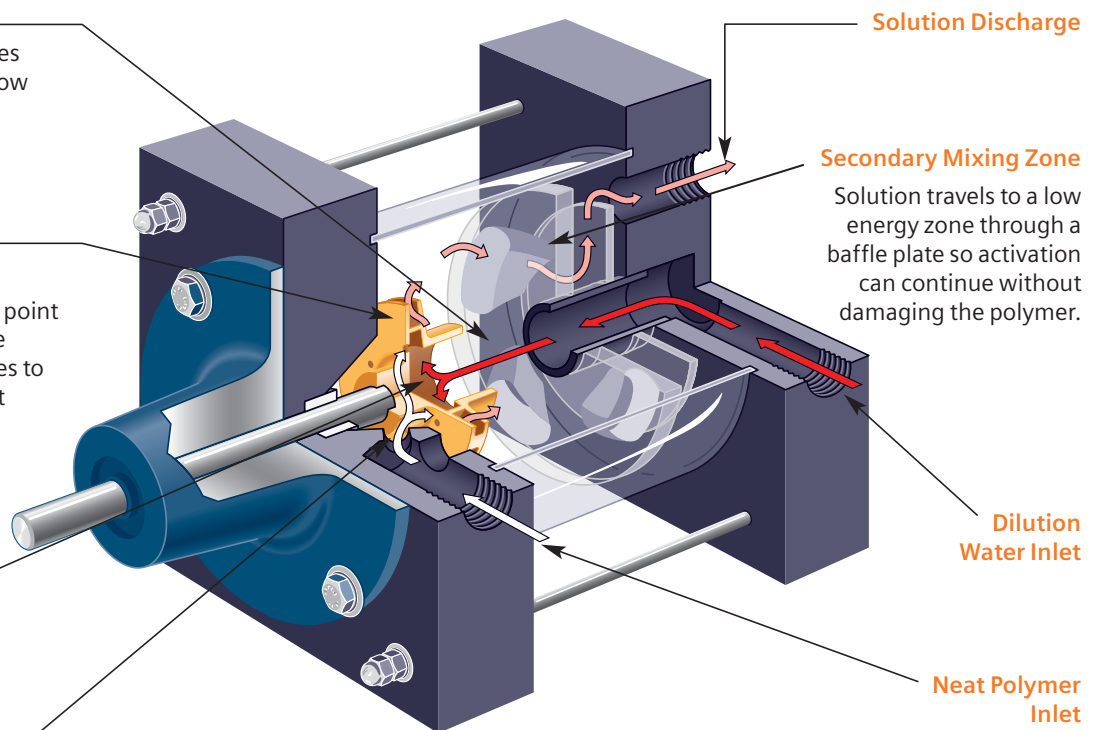

Six sizes cover output ranges from 0.1 to 200 USGPM. Choose between 14 diaphragm, gear, or progressive cavity polymer pumps. The PolyBlend® M Series system's rugged design has been proven in the harshest environments: pulp and paper mills, mining operations, etc. The open frame permits quick and easy maintenance without disassembly.

M Series Model Numbering Guide

The model numbers for the M-Series units can be generated as follows:

Example: M 2 4 0 0 - P 1 0 A B - V

Water Flow Rate

in GPH (LPH)
 240/(912)
 600/(2280)*
 1200/(4540)
 2400/(9120)
 6000/(380 LPM)
 12000/(760 LPM)

Pump Type and Output in LPH (GPH)

Diaphragm

D1.5/(.4)
 D3.8/(1)
 D9.5/(2.5)
 D15.2/(4)
 D38/(10)

Gear

G68/(18)
 G137/(36)
 G228/(60)
 G760/(200)
 G2508/(660)

Progressive Cavity

P38/(10)
 P114/(30)
 P190/(50)

Options

V - Variable speed mixer

Controls

A - On-Off-Remote
 B - Microcontroller
 C - Flow Proportional

Voltage

A - 115VAC/60Hz/1ph
 B - 460VAC/60Hz/3ph
 C - 230VAC/60Hz/1ph

* Model Number is "M601"